

Z18162/...

Konturschiebereinheit
Contour slide unit
Unité de coulisseau

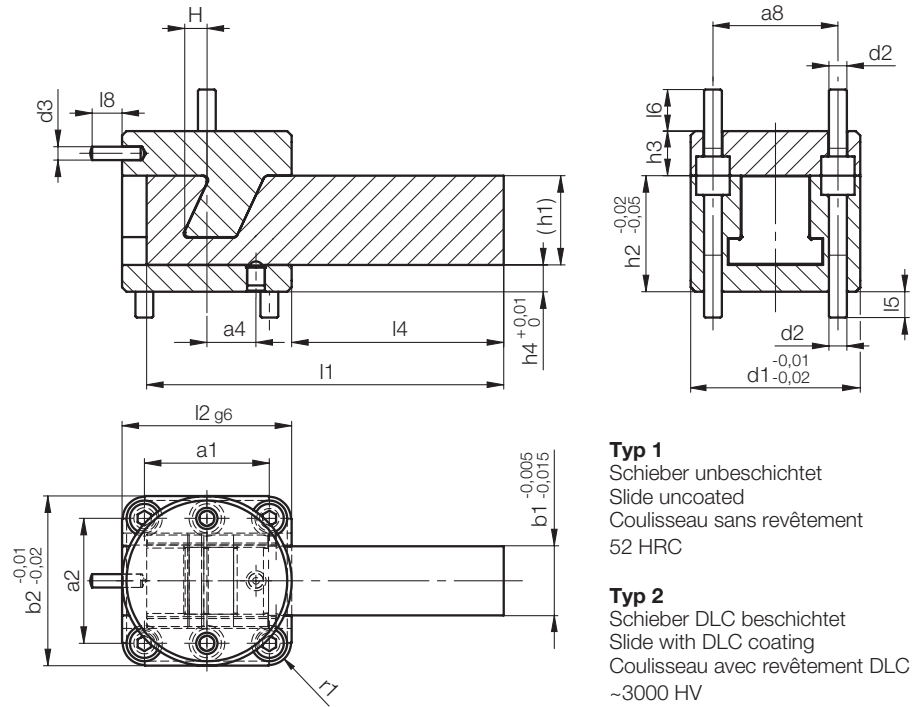

- Typ 1**
Schieber unbeschichtet
Slide uncoated
Coulisseau sans revêtement
52 HRC
- Typ 2**
Schieber DLC beschichtet
Slide with DLC coating
Coulisseau avec revêtement DLC
~3000 HV

H	r1	h4	h3	h2	a8	a4	a2	a1	b2	l8	l6	l5	l4	l2	d3	d2	d1
3,2	4	6	8	22	22	8	22	22	32	6,9	7,4	6,4	36	32	4	M3	32
3,9	5		10	24	24		24	24	34	8,9	9,4	4,4	39	34			34
5,5	8	7	12	30	28	12	30	30	46		12,4	6,4	53	46		M6	46
4,6	9	8		28	32	14	36	36	52	11,1		8,4	60	52	5		52
6,2	10	9	16	34	36	16	38	38	56			7,4	67	56			56
6,7		12		42	44	20	44	44	68	13,4	17,6	11,6	84	68	6	M8	68
10			20	52	56	22	56	56	76				95	76			76
3,2	4	6	8	22	22	8	22	22	32	6,9	7,4	6,4	36	32	4	M3	32
3,9	5		10	24	24		24	24	34	8,9	9,4	4,4	39	34			34
5,5	8	7	12	30	28	12	30	30	46		12,4	6,4	53	46		M6	46
4,6	9	8		28	32	14	36	36	52	11,1		8,4	60	52	5		52
6,2	10	9	16	34	36	16	38	38	56			7,4	67	56			56
6,7		12		42	44	20	44	44	68	13,4	17,6	11,6	84	68	6	M8	68
10			20	52	56	22	56	56	76				95	76			76
3,2	4	6	8	22	22	8	22	22	32	6,9	7,4	6,4	36	32	4	M3	32
3,9	5		10	24	24		24	24	34	8,9	9,4	4,4	39	34			34
5,5	8	7	12	30	28	12	30	30	46		12,4	6,4	53	46		M6	46
4,6	9	8		28	32	14	36	36	52	11,1		8,4	60	52	5		52
6,2	10	9	16	34	36	16	38	38	56			7,4	67	56			56
6,7		12		42	44	20	44	44	68	13,4	17,6	11,6	84	68	6	M8	68
10			20	52	56	22	56	56	76				95	76			76
3,2	4	6	8	22	22	8	22	22	32	6,9	7,4	6,4	36	32	4	M3	32
3,9	5		10	24	24		24	24	34	8,9	9,4	4,4	39	34			34
5,5	8	7	12	30	28	12	30	30	46		12,4	6,4	53	46		M6	46
4,6	9	8		28	32	14	36	36	52	11,1		8,4	60	52	5		52
6,2	10	9	16	34	36	16	38	38	56			7,4	67	56			56
6,7		12		42	44	20	44	44	68	13,4	17,6	11,6	84	68	6	M8	68
10			20	52	56	22	56	56	76				95	76			76



Neu/ New/ Nouveau

Typ	b1	h1	l1	Mat	Nr. / No.	
1	10	16	63	1.2343	Z18162/1/ 10x16x 63/ 1.2343	
	11	18	67		11x18x 67	
	12	23	90		12x23x 90	
	15	20	100		15x20x100	
	18	25	112		18x25x112	
	22	30	140		22x30x140	
	31	40	160		31x40x160	
	10	16	63		1.2767	10x16x 63/1.2767
	11	18	67			11x18x 67
	12	23	90			12x23x 90
	15	20	100			15x20x100
	18	25	112			18x25x112
	22	30	140			22x30x140
	31	40	160			31x40x160
2	10	16	63	1.2343	Z18162/2/ 10x16x 63/ 1.2343	
	11	18	67		11x18x 67	
	12	23	90		12x23x 90	
	15	20	100		15x20x100	
	18	25	112		18x25x112	
	22	30	140		22x30x140	
	31	40	160		31x40x160	
	10	16	63		1.2767	10x16x 63/ 1.2767
	11	18	67			11x18x 67
	12	23	90			12x23x 90
	15	20	100			15x20x100
	18	25	112			18x25x112
	22	30	140			22x30x140
	31	40	160			31x40x160

Z18140/...

Varianten, Kombinationen

Variants, combinations

Variantes, combinaisons

